

**glideVALE**  
**protect**

## ROOFING ACCESSORIES



## ROOFING ACCESSORIES: THE PRODUCT RANGE

Glidevale Protect accessories for pitched tile and slate roofs provide a range of solutions which offer better performance than the traditional alternatives.

- Easier to install.
- More dependable.
- Reliably maintain the weatherproof function of the roof covering.
- Relevant products comply with requirements of Dry Fix Standard BS 8612.



**Fulmetal RediRoll/UniRoll Ventilated Dry Ridge & Hip System**, page 3  
is used with conventional ridge and hip tiles to provide both ventilation and weather protection.

**AluFlash Lightweight Flashing**, page 4  
is an environmentally-friendly alternative to lead; very lightweight and easy to form without specialist skills or tools.

**Universal Dry Verge System**, page 5  
for interlocking tiles; avoids the problems of mortar verges, being easily dry-fixed, resistant to wind uplift and not subject to cracking.

**DV Slate Dry Verge System**, page 6  
for natural and artificial slates; offers the same advantages as Universal Dry Verge.

**Universal Dry Fix Valley Trough**, page 7  
provides a flush appearance with free drainage; dry-fixed with all tiles and slates.

**Univalley 125 Valley Trough**, page 8  
provides an open valley for clear drainage; dry-fixed with slates or mortar bedded with tiles.

**Universal Bonding Strip**, page 9  
provides weather protection at the junction between roofs on semi-detached or terraced houses, especially when re-roofing with different materials.

**OFV Eaves Skirt**, page 10  
ensures efficient water discharge into the gutter; avoids sagging and ponding and will not rot.

**G6 Solar Inlet Terminal**, page 11  
provides a reliable means of maintaining the integrity of the roof covering where cables or pipes pass through it, for example to provide connections for solar heating or photovoltaic panels.



## FULMETAL UNIVERSAL VENTILATED RIDGE & HIP SYSTEM



### Description

Protect Fulmetal RediRoll & UniRoll are innovative universal dry-fixed ventilated ridge and hip systems.

With the ventilated roll manufactured entirely from aluminium, the Fulmetal range ensures long term durability and weather resistance, overcoming the potential issues with traditional fabric based roll ridge systems.

### Authority

Can be used to comply with roof space ventilation requirements of Building Regulations Approved Document C2 and BS 5250.



### Advantages

- Provides ventilation between ridge tiles even on flat roof tiles and slates.
  - All-aluminium roll construction is rot-proof.
  - Ventilated, but driving rain resistant.
  - Unique weatherproof design.
  - Unique clip and screw system provides mechanical fixing of the ridge tiles and correct spacing to ensure an even appearance.
  - Handy 6m pack contains all components needed to install the system.
  - Designed to last the lifetime of the roof. ♦
  - Conforms to Dry Fix Standard BS 8612 and BS 5534.
  - Unrestricted use across the UK and Ireland in wind zones 1-5, in accordance to BS 8612 and BS 5534.
- ♦ Subject to installation according to Glidevale Protect fixing instructions.

### Specification clause

Mechanically fixed ventilated ridge and hip system. Provides mechanical fixing of ridge and hip tiles to BS 8612 and BS 5534 together with high level roof ventilation by means of Protect Fulmetal Rediroll / UniRoll.

Fixing system to suit any tile type on both ridges and hips. Install continuously to provide ventilation area equivalent to 5000mm<sup>2</sup>/m\* to comply with Building Regulations Approved Document C2 and BS 5250.

Fix in accordance with manufacturer's instructions.

\*For plain wing angle, capped angle and decorative ridge tiles please contact Glidevale Protect Technical department. Protect Fulmetal RediRoll / UniRoll Ventilated Dry Ridge / Hip system supplied by Glidevale Protect, 2 Brooklands Road, Sale, Cheshire M33 3SS, T: +44 (0)161 905 5700 F: +44 (0)161 905 2085. Email: info@glidevaleprotect.com.

Product	Application	Compliance	Ventilation	Ridge union	Size	Colours
Fulmetal RediRoll	Universal - for all ridge & hip systems (including mono ridge)	Complies with BS 5250, BS 8612 & BS 5534	Continuous 5000mm <sup>2</sup> /m	✗	Width, 300mm Length, 6m	Terracotta, Grey
Fulmetal UniRoll	Universal - for all ridge & hip systems	Complies with BS 5250, BS 8612 & BS 5534	Continuous 5000mm <sup>2</sup> /m	✓	Width, 300mm Length, 6m	Grey

### Fulmetal RediRoll / UniRoll with half round ridge and pantiles

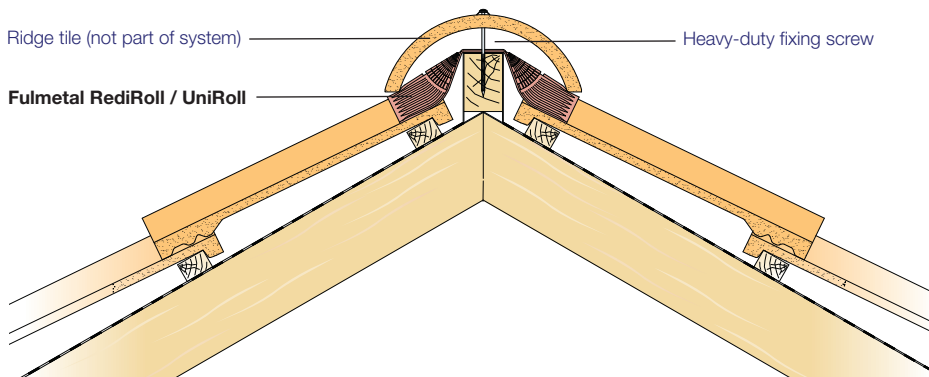

## ALUFLASH LIGHTWEIGHT FLASHING



### Description and application

Protect AluFlash is a revolutionary and environmentally-friendly alternative to lead as a weathering flashing material for buildings. It incorporates all the useful features of lead but eliminates those that are undesirable.

It is aluminium-based and available in two unique surface finishes depending on the application.

### Advantages

- Lightweight, easy and safe to handle.
- Designed to last the lifetime of the roof. ♦
- Easy to form over a range of roof profiles without the need for specialist skills or tools.
- Both AluFlash product variants have been durability tested and have been used in Europe for many years as flashing materials.
- Non-toxic. No potential hazards for installers and no contamination of run-off water.
- Environmentally friendly. Suitable for rainwater harvesting systems.
- 6% of the weight of code 4 lead, providing health and safety benefits for installers.
- AA fire rating, enabling unrestricted use.
- Integral self-adhesive backing eliminates the risk of wind uplift which might allow water penetration.
- Recyclable backing sheet to keep adhesive clean until final installation.
- Highly durable surface finish which does not oxidise, stain or require patination oil.
- Independently certified by BM Trada.

### Material

AluFlash is a combination of highly durable aluminium sheet with a solvent lacquer upper surface and an adhesive butyl backing with high levels of tack to prevent wind uplift.

### Sizes

Roll length: 5m.

Roll widths: 150, 200, 250, 300, 350, 400, 450, 500, and 600mm.

Thickness: 4.1mm (cross-corrugated), 0.65mm (embossed).

### Finishes

Colour: lead grey or terracotta.

#### Cross-corrugated finish

Designed for use where the flashing has to be moulded over and around complex shapes such as profiled roof tiles and corner junctions.

The unique cross-corrugation pattern allows the AluFlash to curve and bend in more than one direction at once.

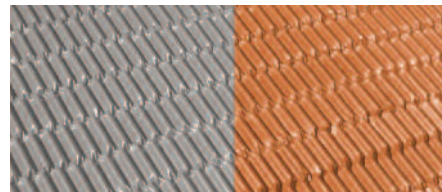

#### Embossed finish

Designed for applications requiring less complex shaping such as pitched roof valleys, secret gutters, soakers for slates and double-lap tiles, and box gutters.



### Specification clause

Flashings to be Protect AluFlash solvent lacquer-coated aluminium sheet with adhesive butyl backing.  
Finish: embossed / cross-corrugated.  
Protect AluFlash supplied by Glidevale Protect, 2 Brooklands Road, Sale, Cheshire M33 3SS,  
T: +44 (0)161 905 5700  
F: +44 (0)161 905 2085.  
Email: info@glidevaleprotect.com.

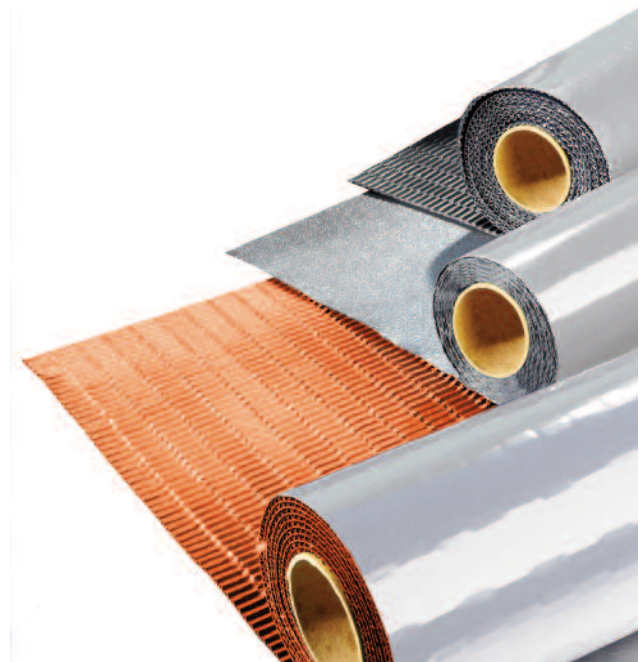

♦ Subject to installation according to Glidevale Protect fixing instructions.

## UNIVERSAL DRY VERGE SYSTEM



### Description and application

The Protect Universal Dry Verge system is compatible with all interlocking metric sized roof tiles and designed to overcome the problems of traditional mortar bedding, such as cracking and long term maintenance.

Its unique ambidextrous patented fixing mechanism locks the units in place whilst allowing lateral and vertical adjustment to accommodate differing tile profiles.

Truly universal, the units are ambidextrous for either left or right verges offering significant advantages for ordering and stockholding purposes.

### Components



Eaves Closure unit

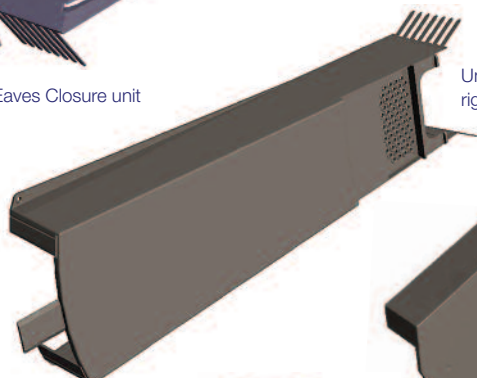

Universal Verge unit, right or left hand



Half Round Ridge Cap

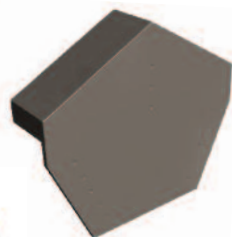

Angled Ridge Cap



Dry Verge Batten End Clip

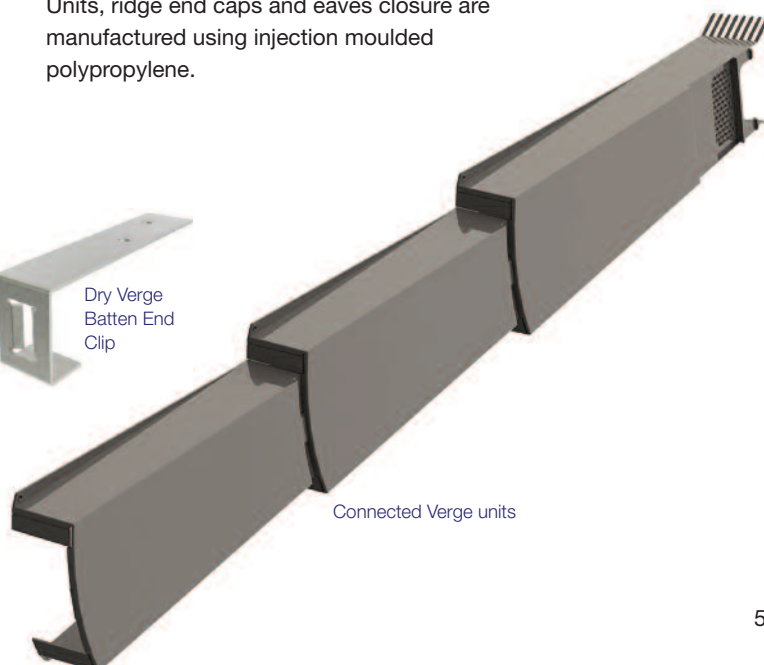

Connected Verge units

### Advantages

- Provides full wind uplift and weather protection.
- Mechanically fixed, no maintenance required.
- Quick and easy to fix, no special skills or tools required.
- All weather fixing, no adhesive or sealants required.
- Compatible with all interlocking metric sized roof tiles at batten gauges from 315mm to 345mm.
- Compatible with all mortar or dry fixed ridge systems.
- Available in black, brown or grey in packs of 10.
- Retains the traditional stepped appearance of the roof tiles.
- Meets the requirements of BS 5534 for mechanical fixing.
- Designed and developed under ISO 9001 Quality Management Systems.
- UV and heat resistant.
- Prevents entry of birds and large insects.
- Unaffected by differential movement or settlement
- Dry verge batten end clip available separately.

### Authority

Can be used to comply with Building Regulations.

### Material and composition

Units, ridge end caps and eaves closure are manufactured using injection moulded polypropylene.

### Specification clause

Install Protect Universal Dry Verge System at roof verges to provide continuous cover over batten ends and tiles to protect against wind uplift and driving rain. System to include ambidextrous right or left hand units and ridge end caps in injection moulded UV stabilised polypropylene and eaves closure in injection moulded polypropylene to exclude birds and large insects. Fix mechanically in accordance with manufacturer's instructions. Protect Universal Dry Verge System supplied by Glidevale Protect, 2 Brooklands Road, Sale, Cheshire M33 3SS, T: +44 (0)161 905 5700 F: +44 (0)161 905 2085. Email: info@glidevaleprotect.com.

## DV SLATE DRY VERGE SYSTEM



### Description and application

The new Protect DV Slate Dry Verge System offers continuous cover over batten ends and slates, being mechanically fixed to ensure full protection from wind uplift, driving rain and water ingress. Now featuring a wider capacity to accommodate slates up to 10mm in thickness, this dry fix verge system is designed for simple modular construction in full compliance to BS 8612.

Supplied in 2.44m lengths, the system is complete with a dry verge connector unit for installation up to the ridge as well as right and left handed eaves stop ends for clipping onto the end of the verge extrusion.

With dry fix systems now a more popular alternative to the traditional mortar bedded verges which may crack due to the differential movement, the Protect DV Slate Dry Verge system offers easy installation and a full solution to protect the edge of the roof.

### Authority

Can be used to comply with Building Regulations, BS 5534 and BS 8612.

### Material and composition

Verge extrusion is manufactured in PVC-U in 2.44m long sections.

Connector unit and eaves stop ends are made from injection-moulded polypropylene.

All components are matt slate grey, matched to RAL 7016 and UV stabilised.

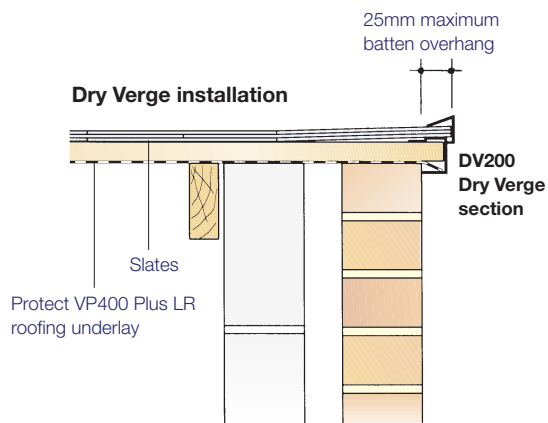

### Advantages

- Suitable for natural and artificial double-lap slates up to 10mm in thickness.
- Requires no maintenance once installed.
- Full wind uplift and water protection.
- UV stabilised and heat resistant, matched to RAL 7016.
- Self-draining – any rainwater entering the system is carried away from the roof covering and directly into the gutter.
- Quick fixing, completely dry-fixed and able to be installed in any weather.
- Fully compliant with BS 8612.
- No adhesive, sealant or special tools are required.
- Modular construction, featuring a verge extrusion, unobtrusive connector units and eaves stop ends, designed to prevent ingress of birds.
- Self-draining: any rainwater which enters the system is carried away from the roof covering and directly into the gutter.
- Available in packs of 10 as separate items: DV200, DV201, DV202 and DV203.

### Specification clause

Install Protect DV Slate Dry Verge system at roof verges to provide continuous cover over batten ends and slates to protect against wind uplift and driving rain. System to include extruded PVC-U edge sections, preformed dry verge connector unit for installation up to the ridge and eaves stop ends to prevent ingress of birds. Fix mechanically in accordance with manufacturer's instructions. Protect DV Slate Dry Verge System to be supplied by Glidevale Protect, 2 Brooklands Road, Sale, Cheshire M33 3SS, T: +44 (0)161 905 5700 F: +44 (0)161 905 2085. Email: info@glidevaleprotect.com.

DV200 Dry Verge section length 2.44m



DV201 Dry Verge connector unit



Eaves stop end DV202 right hand DV203 left hand

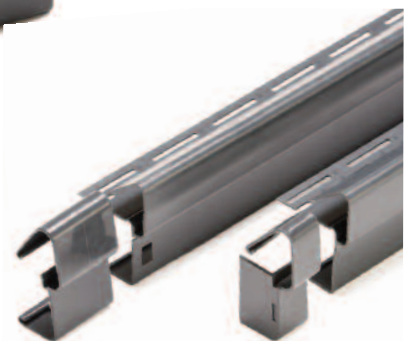

Note: Capped end ridge tiles available from most tile manufacturers can also be used to finish the gable end.



## UNIVERSAL DRY FIX VALLEY TROUGH

### Description and application

Glidevale Protect's innovative second generation Universal GRP Dry Fix Valley Trough adds to the extensive range of dry fix solutions.

Dry fixing is quicker, less dependent on site skills and guarantees a neater finish than mortar bedding.

### Advantages

- Universal - accommodates roof pitches from 17.5° and above, and compatible with flat or profiled tiles and slates, providing a flush appearance.
- One size - 3 metres. Traditionally popular length for speedy installation, readily cut on site.
- Positive fix to valley batten. Substantial 25mm vertical weather check which also provides strong fast fix to valley batten.
- Unique shape assists with free drainage

with secure protection against water ingress.

- Non-toxic and environmentally friendly. No potential hazards for installers and no contamination of run-off water. Suitable for rainwater harvesting systems.
- No resale value to a prospective thief.
- Integral 'Gel' coat. Proven to provide increased durability.
- Fire resistant. Designated AB fire rating to BS 476: Part 3.
- Does not streak or stain tiles.
- Available in packs of 10.

### Material and composition

Universal Dry Fix Valley Trough is manufactured from 1.2mm thick GRP in 3 metre lengths.

### Appearance

Colour: lead grey.

### Specification clause

Install Protect Universal Dry Fix Valley Trough at roof valleys. Valley trough to be GRP with gel coat finish, with central weather bar to assist free drainage with secure protection against water ingress.

AB fire rating to BS 476: Part 3.

Mechanically fix in accordance with manufacturer's instructions. Protect Universal Dry Fix Valley trough to be supplied by Glidevale Protect, 2 Brooklands Road, Sale, Cheshire M33 3SS, T: +44 (0)161 905 5700 F: +44 (0)161 905 2085. Email: info@glidevaleprotect.com.

### Plain tiles or slates

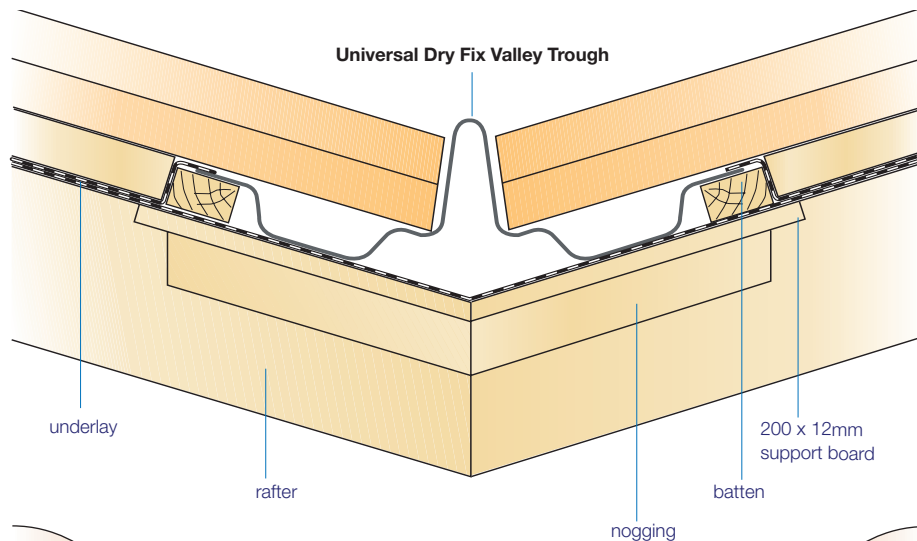

### Profiled tiles

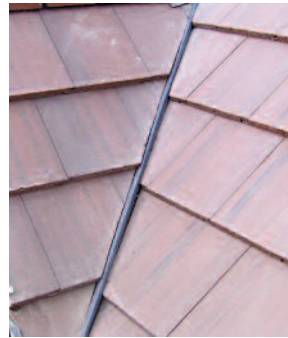
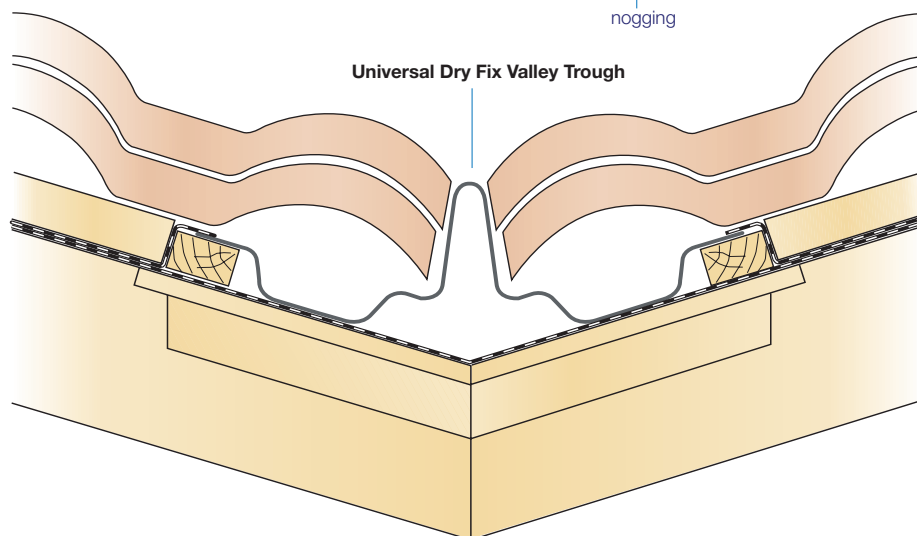

## UNIVALLEY 125 VALLEY TROUGH

### Description and application

A valley is one of the most vulnerable parts of the roof - the Protect Univalley 125 GRP Valley Trough provides a universal solution for valley detailing, offering advantages of economy and performance over valley tiles, concrete troughs and lead valleys.

The Protect Univalley 125 incorporates many design features and has been developed as a universal product for ease of installation, simplified stockholding and minimum wastage.

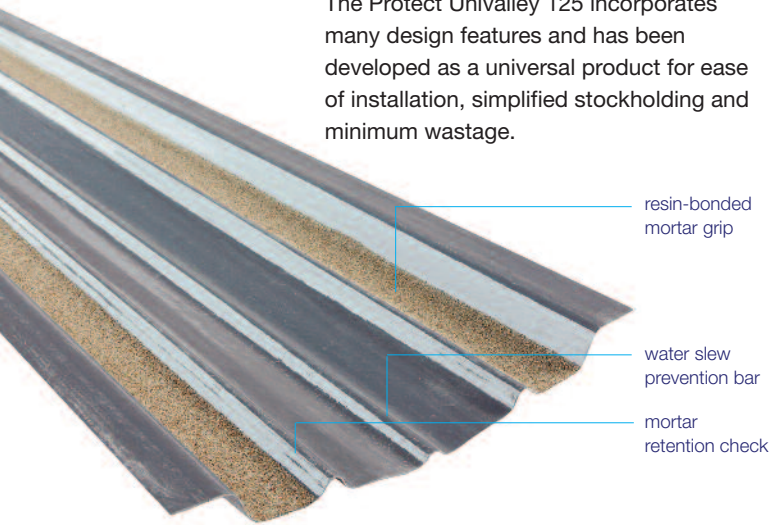

Tests undertaken by Brunel University, Uxbridge, show that a clear water channel of 125mm is necessary for roof drainage areas greater than 25 square metres.

Compatible with either slates or tiles, the Univalley 125 has a 125mm clear water channel to ensure optimum performance and incorporates a 'gel' coat, proven to provide increased durability.

### Application showing both slate and tile

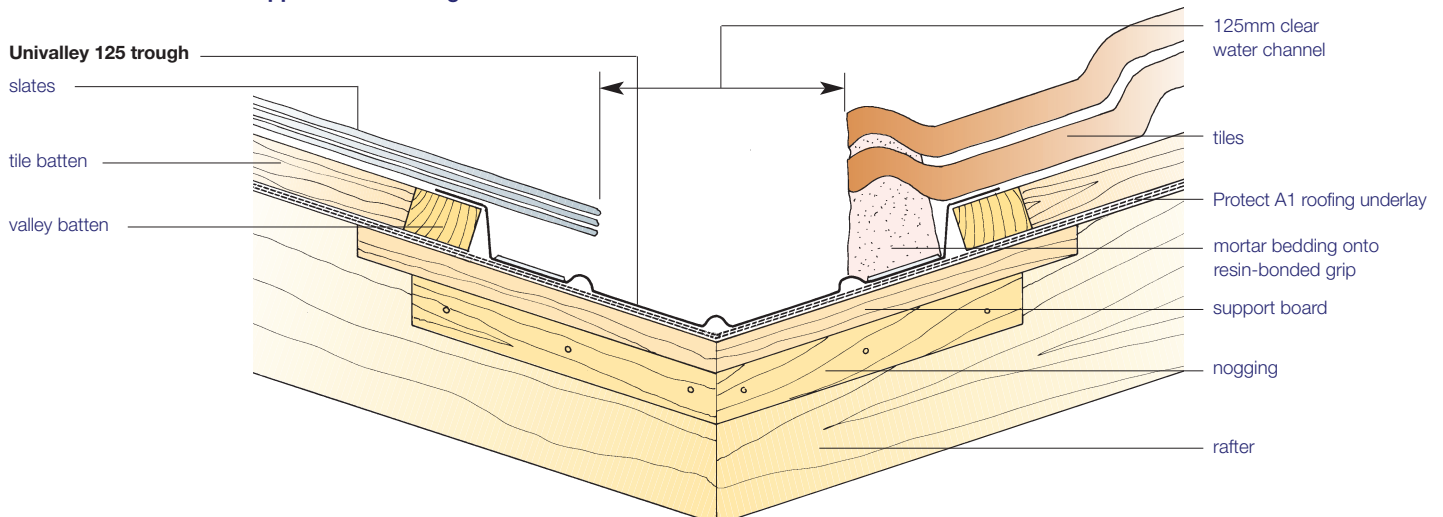

### Material and composition

Univalley 125 Valley Trough is manufactured from GRP in 3 metre lengths.

### Advantages

- Universal for slate or tile. Can be dry fixed with all slates including Redland Cambrian and Marley Monarch or wet bedded with all concrete and clay roof tiles.
- One size – 3 metres. Traditionally popular length for speed of installation, with universal width. Readily cut on site.
- Integral mortar retention check. Holds 'green' mortar preventing slippage into open valley during fixing. Provides secondary weather bar against rain penetration.
- Positive fix to valley batten. Substantial 25mm vertical weather check which also provides strong fast fix to valley batten.
- Resin bonded wide mortar grips. Ensures maximum adhesion for mortar.
- Deep valley section and shape. Secure protection against water ingress.
- Integral water slew prevention bar. Tested to enhance water discharge allowing use with dissimilar roof pitches up to 15 degrees difference.
- Integral 'Gel' coat. Proven to provide increased durability.
- Fire Resistant. Designated AB rating to BS 476: Part 3.
- Available in packs of 10.

### Specification clause

Install Protect Univalley 125 Valley Trough at roof valleys. Valley trough to be GRP with gel coat finish, provide 125mm wide clear water channel, incorporating water slew prevention bar, water checks, mortar retention check and resin bonded mortar grips. Fix in accordance with manufacturer's instructions. Protect Univalley 125 GRP Valley Trough to be supplied by Glidevale Protect, 2 Brooklands Road, Sale, Cheshire M33 3SS, T: +44 (0)161 905 5700 F: +44 (0)161 905 2085. Email: info@glidevaleprotect.com.



## UNIVERSAL BONDING STRIP

### Description and application

The Protect Universal GRP Bonding Strip provides even greater protection at the junction between old and new roofing on semi-detached or terraced properties.

The design incorporates many features to provide an effective and economical solution to the problem of weathering the junction at party walls when properties are re-roofed at different times with incompatible materials.

### Advantages

- Universal design. Can be fitted with any combination of double-lap or interlocking slates, clay and concrete tiles.
- Design ensures slates don't 'kick up'. Improves weather resistance. Enhances appearance of roof.
- Secret or open gutter for efficient discharge of water. Unobtrusive for sheltered locations.

- Positive gutter size with 75mm wide gutter channel and 20mm upstands to ensure swift discharge of rainwater.
- Independent mortar fixing positions. Resin bonded for maximum adhesion. Allows for differential movement between dissimilar roof materials.
- Design prevents battens being carried over division wall. Meets the requirement of BS 8000 (workmanship) for firebreak walls.
- Secondary 10mm storm bars. Enhanced weatherability.
- Integral mortar retention. Holds 'green' mortar preventing slippage into open gutter during fixing.
- Integral 'Gel' coat. Proven to provide increased durability.
- Dry fix option. Slates can be dry fixed without the risk of water penetration.
- One size – 3 metres. Lightweight, easy to handle, readily cut on site.
- Fire resistant. Designated AB rating to BS 476: Part 3. Can be used in a fire separation wall detail.
- Available in packs of 10.

### Specification clause

Install Protect Universal Bonding Strip at junction between old and new roofing. Bonding strip to be GRP with gel coat finish, and to incorporate a gutter channel 75mm wide with 20mm upstands, 10mm secondary storm bars, and mortar channels with resin bonded mortar grips. Fix in accordance with manufacturer's instructions. Protect Universal Bonding Strip to be supplied by Glidevale Protect, 2 Brooklands Road, Sale, Cheshire M33 3SS, T: +44 (0)161 905 5700 F: +44 (0)161 905 2085. Email: info@glidevaleprotect.com.

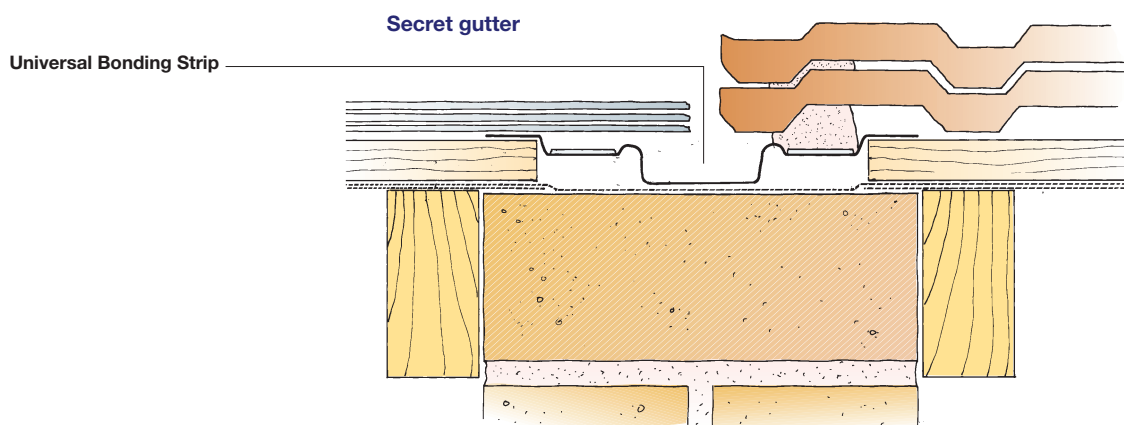
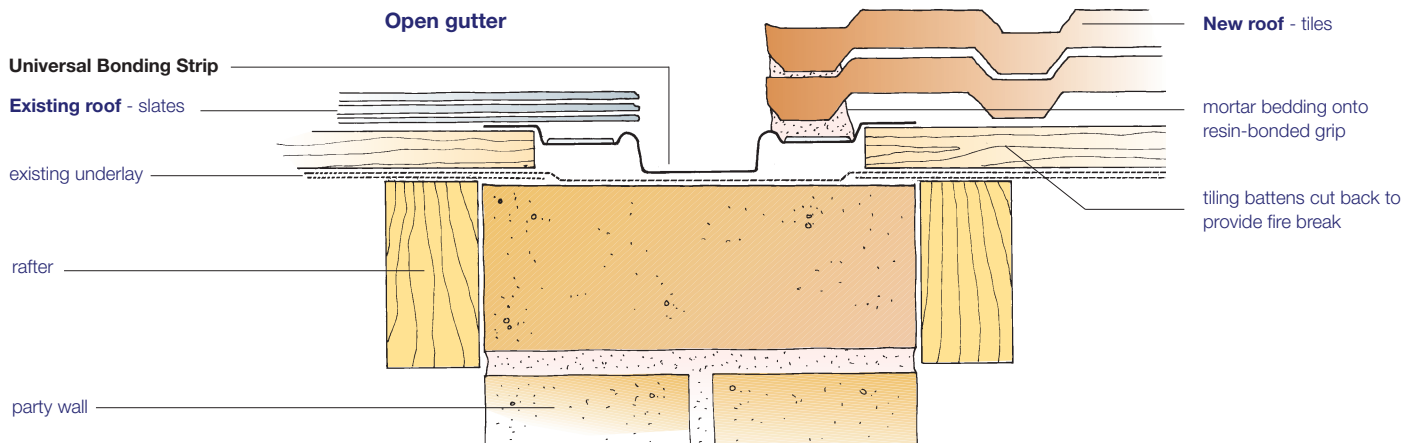
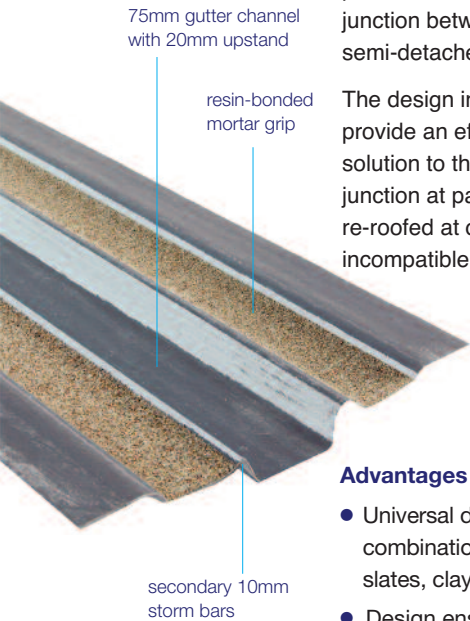

## OFV EAVES SKIRT



### Description and application

The Protect OFV Eaves Skirt replaces both the underlay into the gutter and the traditional tilting fillet. It is designed to avoid sagging and ponding of the underlay behind the fascia and ensure correct water discharge into the gutter.

### Advantages

- Avoids sagging and ponding and will not rot in the gutter unlike bitumen derivatives.
- Robust 1.5mm PVC-U construction resists impact and UV degradation over time.
- Prevents wind noise under load.
- For use with Glidevale 10mm or 25mm over fascia ventilators or directly onto fascia board.
- Flexible design allows access to the fascia board for fitting gutter brackets.
- Supplied in 1.5m lengths, 10 lengths per pack.
- Suitable for new build or refurbishment applications.

### Authority

Can be used to comply with Building Regulations Approved Document C and BS 5534.

### Specification clause

Install Protect OFV Eaves Skirt to avoid sagging and ponding of underlay behind fascia and ensure correct water discharge into the gutter. Protect OFV Eaves Skirt to be extruded in UV stabilised PVC-U to provide a long term durable solution.

Protect OFV Eaves Skirt to be supplied by  
Glidevale Protect,  
2 Brooklands Road, Sale,  
Cheshire M33 3SS,  
T: +44 (0)161 905 5700  
F: +44 (0)161 905 2085.  
Email:  
info@glidevaleprotect.com.

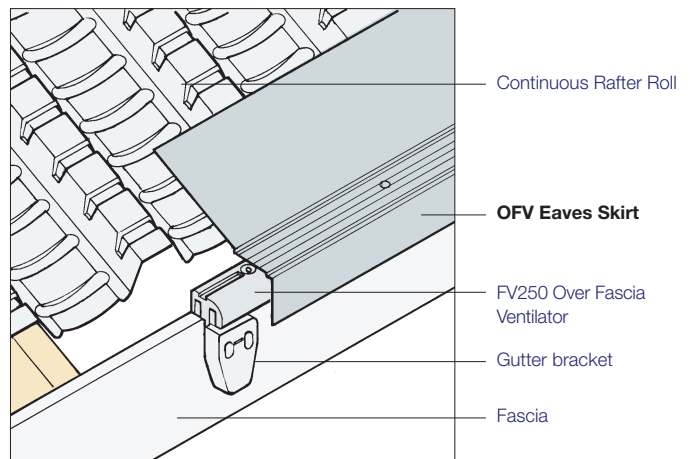
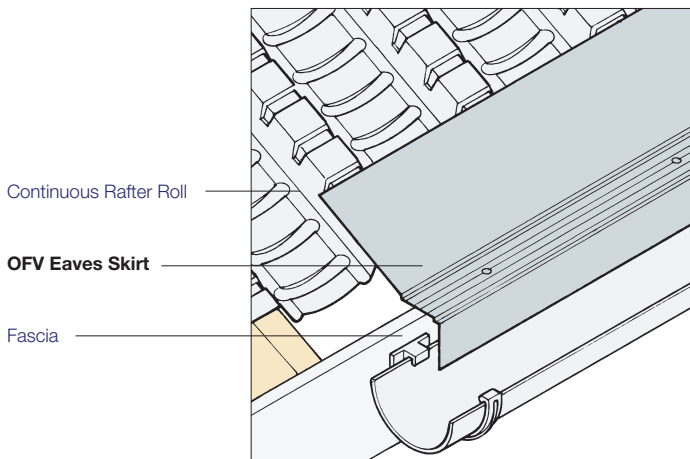
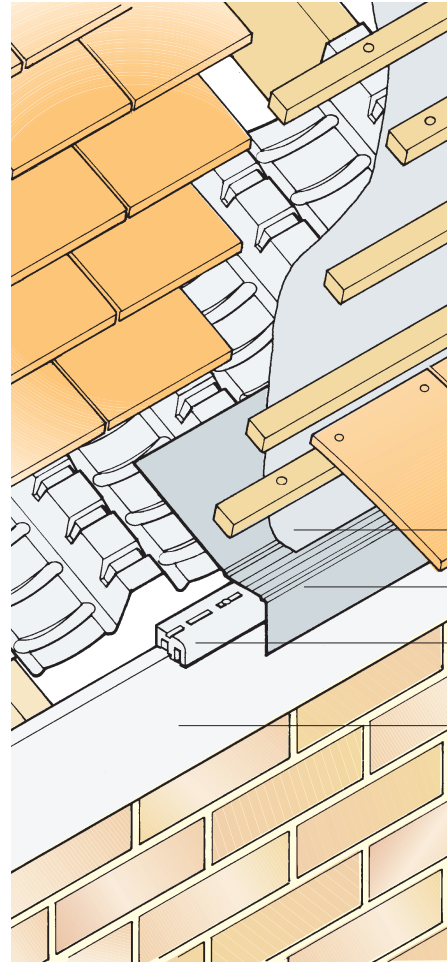

## G6 SOLAR INLET TERMINAL



G6 for slates

### Description and application

The Protect G6 Solar Inlet Terminal has been designed to guarantee the integrity of the roof when cables and pipes are routed through the tiles/slates and roofing membrane.

Ideal for solar panel installations.

### Advantages

- Versatile suits virtually all single lap interlocking roof tiles\*.
- G6 also available for slates (soaker base plate) and plain tiles. Specific profiles available to order.
- Easy installation.
- Allows user defined holes to be drilled to accommodate different cable/pipe diameters.
- Five colours available: red, brown, grey, terracotta and red streak.
- Supplied with underlay opening protector.
- Low profile cowl for installation under retro fit photovoltaic panels.
- Compressible foam filler ensures driving and deluge rain resistance.
- Designed and developed under ISO 9001.
- Available in packs of 5.

### Specification clause

Install Protect G6 (versatile/slate soaker/ plain tile, delete as appropriate) inlet as part of the roof covering to provide weather protected inlet[s] for cables or pipes as required.

Fix in accordance with manufacturer's instructions. Protect G6 Solar Inlet Terminal to be supplied by Glidevale Protect, 2 Brooklands Road, Sale, Cheshire M33 3SS, T: +44 (0)161 905 5700 F: +44 (0)161 905 2085. Email: info@glidevaleprotect.com.

\*Not suitable for use with Plain Tiles, Clay Single Pantiles, Forticrete Centurion Tiles, Goxhill Gaelic Tiles or Interlocking Slates.

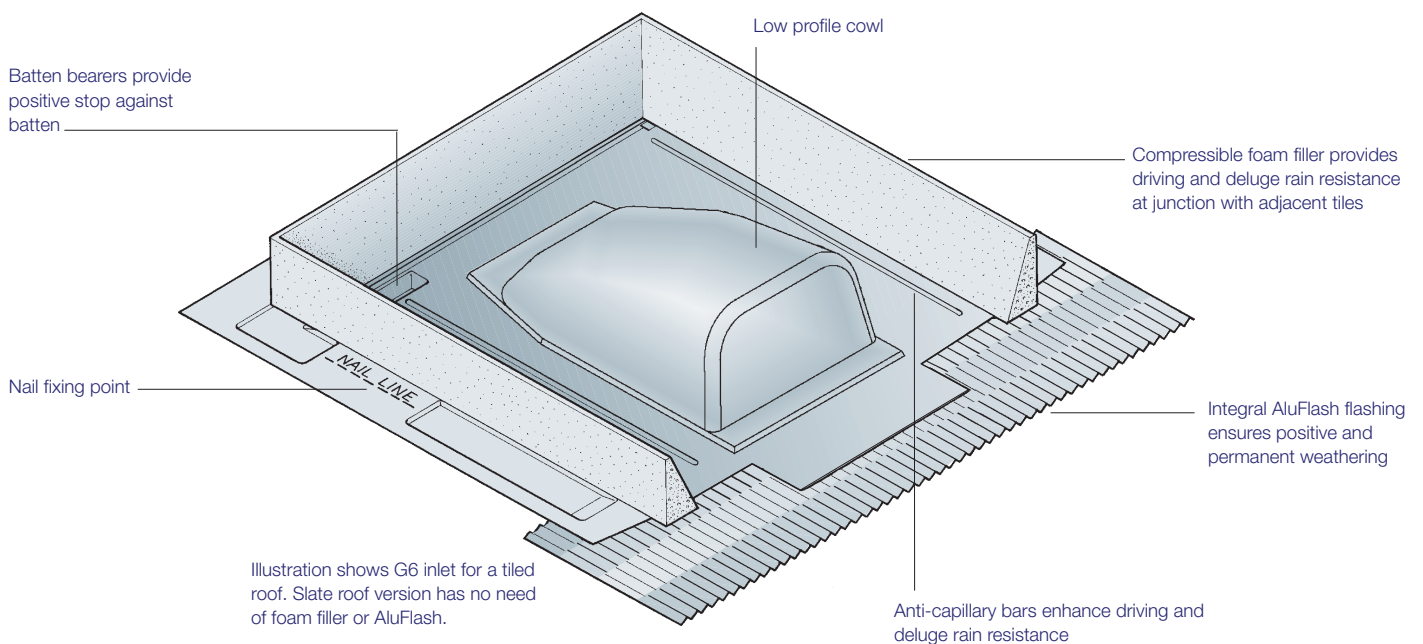



### ROOFING VENTILATION RANGE

Suitable for all tile and slate roofs, the wide array of Glidevale Protect ventilation products helps reduce the condensation risk for the full cold or warm roof structure, delivering the required airflow requirements when used in conjunction with roofing underlays.

*The range includes:*

**G Range Slate & Tile Ventilators**

**In-Line® Slate, Tile & Ridge Ventilators**

**Universal In-Line® Slate & Tile Ventilators**

**Versa-Tile G5 Ventilator / Terminal**

**RV Rafter Ventilators**

**Fascia Ventilators**

**Soffit Ventilators**

**Abutment Ventilator**

**Monovent (Lean to Roof) Ventilator**

**Fulmetal RediRoll Ventilated Dry Fix Ridge Hip system**

### A COMPREHENSIVE CHOICE OF ROOFING UNDERLAYS

Whatever your pitched roofing project, Glidevale Protect's broad collection of underlays has it covered. Providing the complete solution for all types of slate or tile roofs to meet the key requirements of water tightness, strong wind uplift resistance and condensation control, Glidevale Protect gives unrivalled choice in specification and complete peace of mind.

#### Vapour Permeable & Airtight (Type LR)

Protect VP400 Plus LR  
Protect Zytec  
Protect VP300

#### Impermeable & Airtight (Type HR)

Protect A1T3 Plus  
Protect A1  
Protect Wunderlay

#### Air & Vapour Permeable (Type LR)

Protect Viking Air

### ROOFING ACCESSORIES RANGE

A full package of roofing accessories for all tile and slate roofs is also available, designed to complement the roofing product collection and offering an ideal alternative to traditional products.

*The range includes:*

**AluFlash lead-free alternative flashing**

**Universal Dry Verge Systems for slates and interlocking tiles**

**Universal Dry Fix Valley Trough**

**Universal Valley Trough**

**Universal Bonding Strip**

**OFV Eaves Skirt & Eaves Comb**

**Solar Inlet Terminal**

### CONSTRUCTION DIVISION

A whole range of product options are available from Glidevale Protect's Construction Division. This includes a range of external wall membranes, internal airtightness and vapour control membranes for walls, floors and ceilings, sealing tapes, cavity trays, underfloor and cavity wall ventilation, intelligent passive stack ventilation - iPSV®, trickle vents and loft access hatches.

#### Glidevale Protect has it covered.

For more information, visit our website at: [www.glidevaleprotect.com](http://www.glidevaleprotect.com)

For further, detailed technical advice please contact the Glidevale Protect Technical department at: [technical@glidevaleprotect.com](mailto:technical@glidevaleprotect.com)

Stockist's stamp

### GLIDEVALE PROTECT

2 Brooklands Road, Sale, Cheshire M33 3SS  
T: +44 (0)161 905 5700 F: +44 (0)161 905 2085  
E: [info@glidevaleprotect.com](mailto:info@glidevaleprotect.com)  
W: [glidevaleprotect.com](http://glidevaleprotect.com)

Glidevale Protect maintains a policy of continuous development and reserves the right to amend product specifications without notice.



A division of Building Product Design Ltd. Company Registration No: 3944123



modular & portable  
building association

